



US 20060124664A1

(19) **United States**

(12) **Patent Application Publication**
Spears

(10) **Pub. No.: US 2006/0124664 A1**

(43) **Pub. Date: Jun. 15, 2006**

(54) **APPARATUS FOR DISTRIBUTING A BEVERAGE**

Publication Classification

(76) Inventor: **David J. Spears**, Champaign, IL (US)

(51) **Int. Cl.**
B67D 1/16 (2006.01)

Correspondence Address:
BARNES & THORNBURG
11 SOUTH MERIDIAN
INDIANAPOLIS, IN 46204

(52) **U.S. Cl.** **222/108**

(57) **ABSTRACT**

(21) Appl. No.: **11/301,068**

(22) Filed: **Dec. 12, 2005**

Related U.S. Application Data

(60) Provisional application No. 60/636,324, filed on Dec. 15, 2004.

An apparatus for distributing a beverage includes a dispenser configured to be mounted to a shaft. The shaft is surrounded on a lower portion by a base. The dispenser is arranged having a number of discharge ports mounted in a 360-degree orientation. The discharge port arrangement allows a number of operators to distribute beverage without interfering with each other.

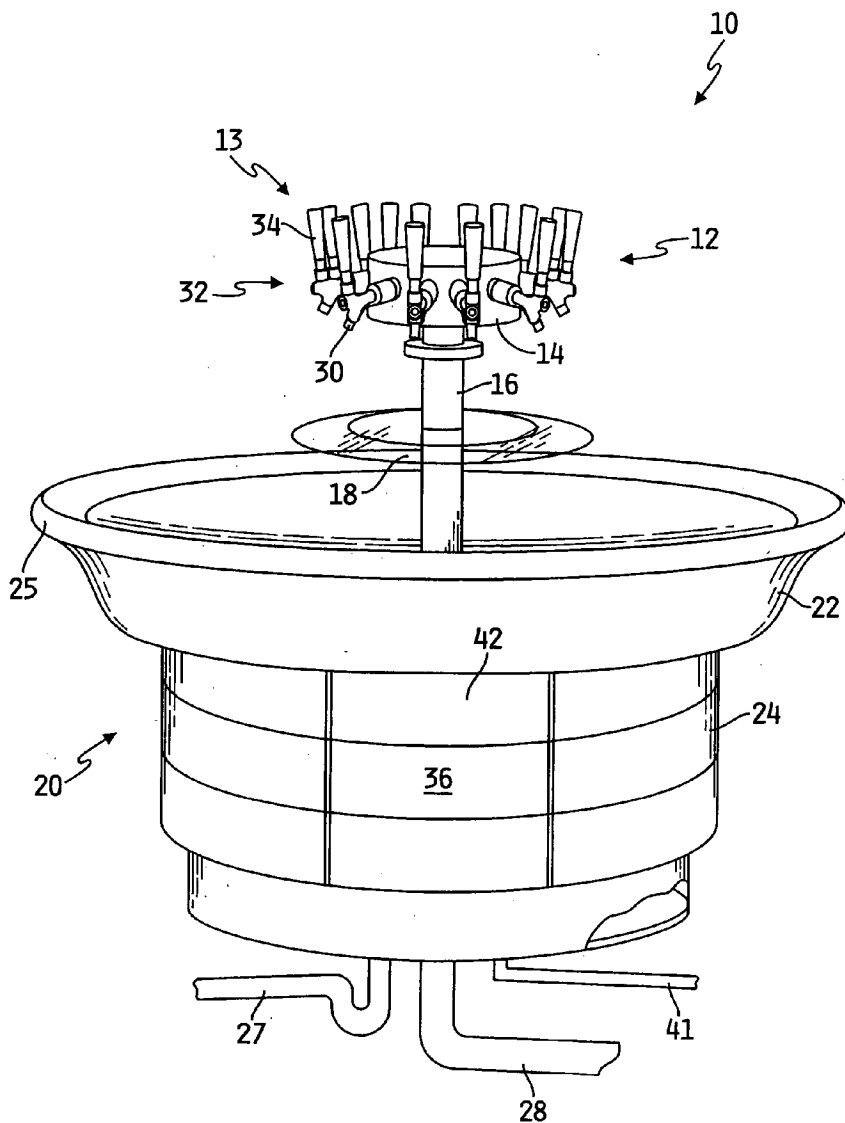

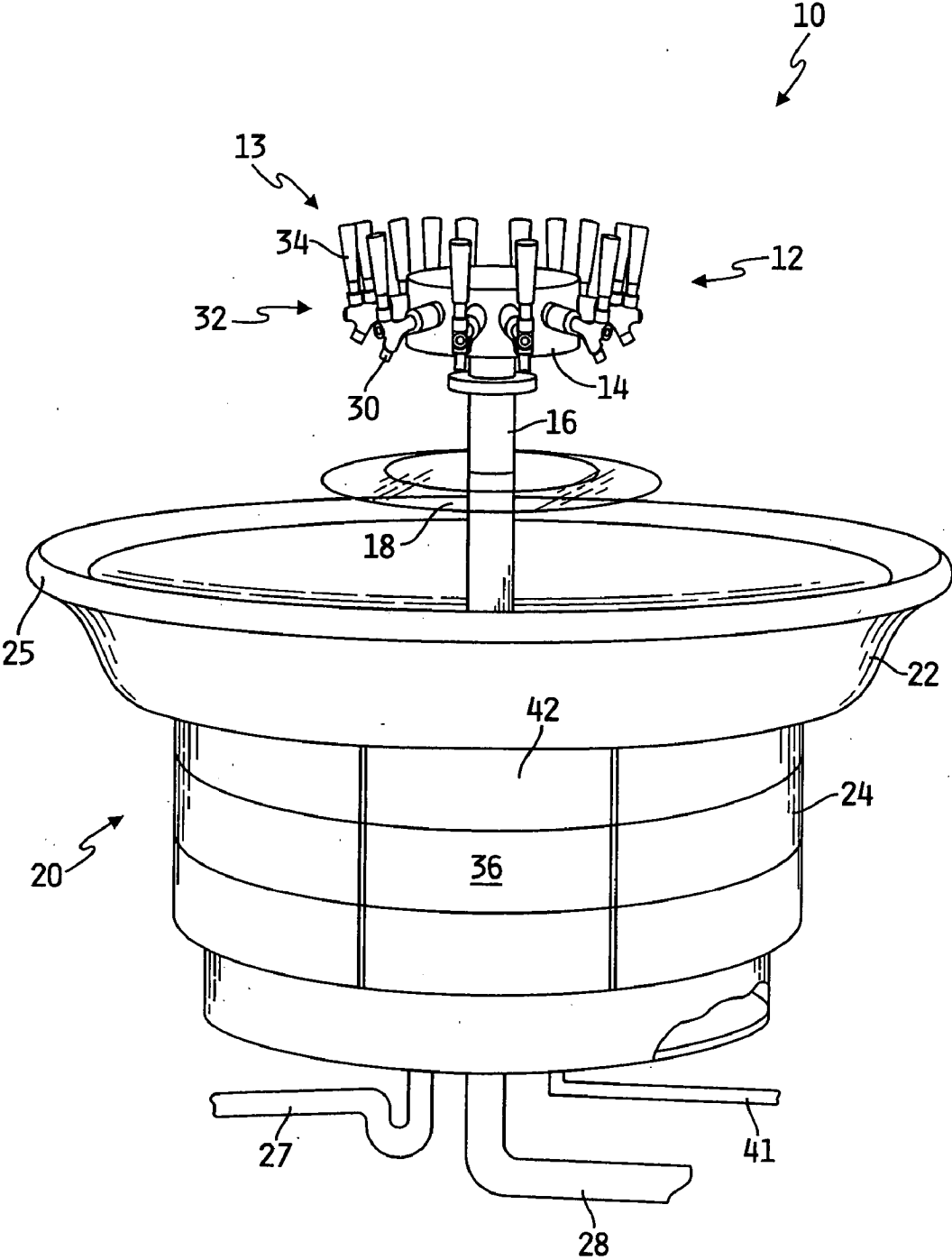

FIG. 1

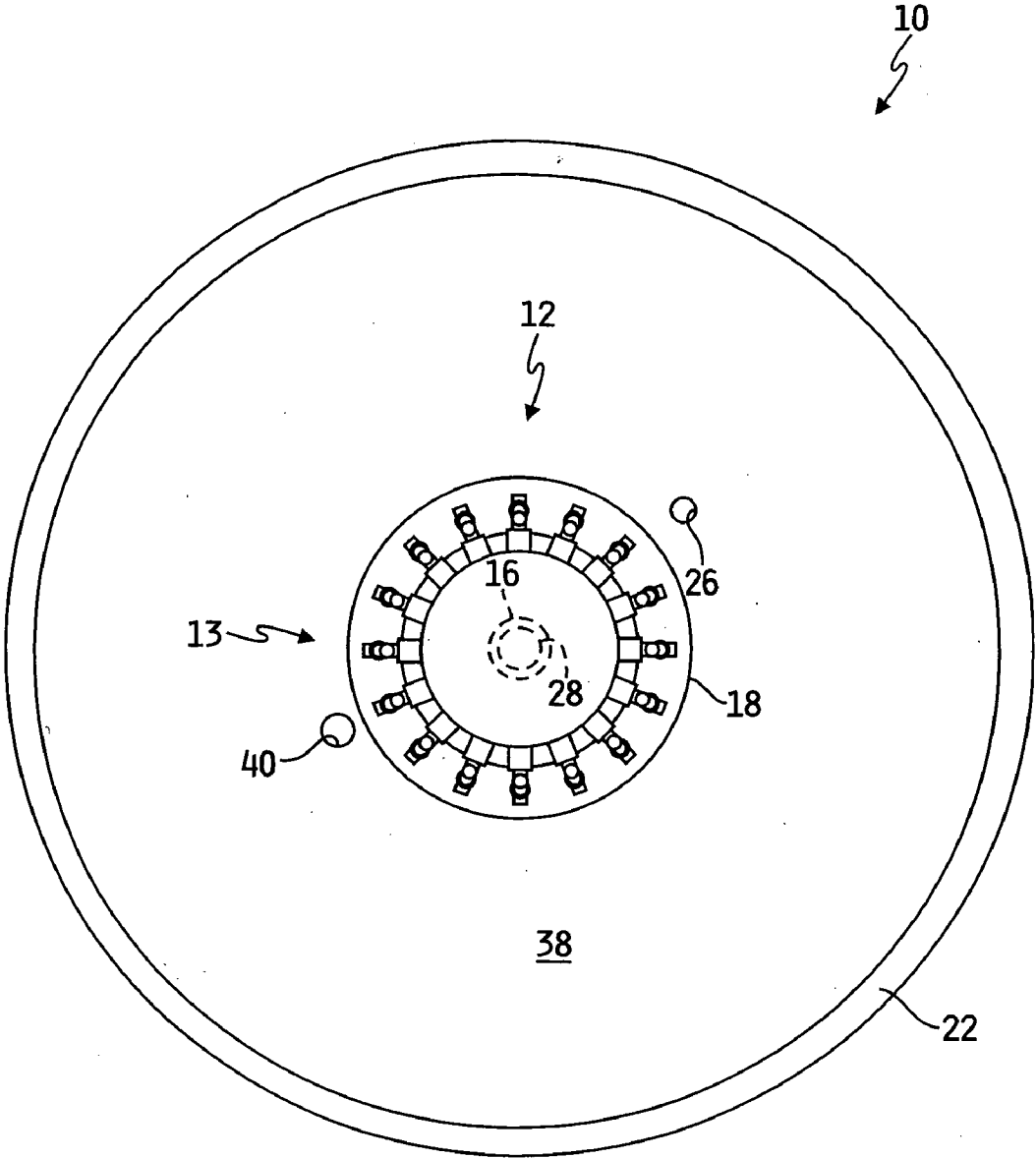

FIG. 2

APPARATUS FOR DISTRIBUTING A BEVERAGE

[0001] This present application claims benefit of U.S. Provisional Patent Application Ser. No. 60/636,324, filed Dec. 15, 2004, which application is hereby incorporated by reference herein.

BACKGROUND

[0002] The present disclosure relates generally to beverage dispensers, and more particularly to fountain-type beverage dispensers.

[0003] Fountain-type beverage dispensers are used in a variety of settings. A number of beverage dispensers allows a greater quantity of patrons to be served simultaneously. Coupling a number of individual dispensers to a single hub or drum allows numerous servers to access the beverage dispensers without interfering with each other.

SUMMARY

[0004] The present disclosure may comprise one or more of the features recited in the claims, and/or one or more of the following features and combinations thereof. An apparatus for distributing a beverage may comprise a dispenser having a drum coupled to an upper portion of a shaft and a number of discharge ports coupled to the drum. The shaft may comprise a hollow cylinder configured to receive a liquid supply tube coupled to one end of a supply source, and on another end, to the number of discharge ports coupled to the drum.

[0005] The dispenser may further include a platform coupled to the shaft below the drum. The platform may provide means for supporting a beverage receptacle so that a server does not have to hold the receptacle when filling it from the discharge ports.

[0006] The dispenser may further include a basin surrounding a lower portion of the shaft to collect any liquid which is spilled in the process of filling the beverage receptacle. The basin may further include a water supply line and a waste outlet. The water supply line may be a pipe configured to deliver tap water to the base for cleaning, for example. The waste outlet may be a pipe configured to allow waste liquids to exit the basin and flow to an appropriate waste collection system.

[0007] Additional features of the disclosure will become apparent to those skilled in the art upon consideration of the following detailed description of illustrative embodiments.

BRIEF DESCRIPTION OF THE DRAWINGS

[0008] **FIG. 1** is a perspective view of the apparatus for distributing a beverage including a number of discharge ports coupled to a drum, the drum coupled to an upper portion of a shaft, the shaft surrounded on a lower portion by a concentrically arranged basin to collect liquids spilled in the distribution process, and the basin being formed to include a hinged door panel, a water supply line, and a waste outlet; and

[0009] **FIG. 2** is a plan view of the apparatus for distributing a beverage of **FIG. 1**, with portions broken away, showing the number of discharge ports arranged in a spaced-apart relationship generally 360 degrees around the drum,

the concentrically arranged basin surrounding a lower portion of the apparatus, and the waste outlet.

DETAILED DESCRIPTION

[0010] For the purposes of promoting an understanding of the principles of the disclosure, reference will now be made to one or more illustrative embodiments illustrated in the drawing and specific language will be used to describe the same.

[0011] Referring to **FIG. 1**, an apparatus for distributing a beverage **10** is shown and includes a dispenser **12**, a shaft **16**, and a basin **20**. Dispenser **12** includes a number of discharge ports **13** coupled to a drum **14**. Drum **14** is coupled to an upper portion of shaft **16** in a conventional manner. A lower portion of shaft **16** is coupled to basin **20**.

[0012] An upper portion of shaft **16** is arranged having drum **14** coupled to the upper portion of shaft **16**, the lower portion of shaft **16** is coupled to basin **20**, and a beverage receptacle platform **18** coupled to shaft **16** therebetween. In the illustrative embodiment, beverage receptacle platform **18** is an annular tray or annular plate **18** formed to include an aperture at its center arranged to receive shaft **16**. Tray **18** extends radially outwardly away from shaft **16** to provide a surface for a server to place a beverage container (not shown) below discharge ports **13** so that the server can fill the container without having to hold the container during the distribution process.

[0013] Illustratively, shaft **16** is formed to include a hollow bore configured to receive a supply tube **28** coupled to a supply source (not shown) located away from apparatus **10**. Supply tube **28** extends through the lower portion of shaft **16** to an upper portion of shaft **16** where it is coupled to discharge ports **13** for fluid communication between shaft **16** and discharge ports **13**.

[0014] Each discharge port **13** includes a spigot **30**, a control valve **32**, and a control valve actuator **34**. Spigot **30** allows a beverage to be dispensed out discharge port **13** to a beverage container. Control valve **32** is configured to control the flow of beverage from supply tube **28** to the beverage container. Control valve actuator **34** is arranged to allow a server to manually operate control valve **32**. In the illustrative embodiment, actuator **34** is a palm-receiving rod.

[0015] Referring now to **FIG. 2**, discharge ports **13** are arranged in a spaced-apart relation to one another around drum **14** in a generally 360-degree orientation. The 360-degree orientation provides means for a number of servers to access dispenser **12** simultaneously so that they do not interfere with each other while filling beverage containers. Illustratively, sixteen ports **13** are shown. However, it is within the scope of this disclosure to include a dispenser **12** having any number of discharge ports **13**.

[0016] Basin **20** includes an outer side wall **36** and a bottom wall **38** cooperating to define an interior region **29**. Outer side wall **36** is configured having an upper portion **22** and a lower portion **24**. Bottom wall **38** is formed to include an outlet **26** associated with a drain pipe **27**. Bottom wall **38** may include an inlet aperture **40** to provide, for example, means for supplying a fresh water source such as an inlet pipe **41**. Upper portion **22** is generally frustoconical in shape having a wide-diameter top end and a narrow-diameter bottom end. Upper portion **22** is coupled to lower portion **24**

to form a unitary structure. Lower portion **24** is generally cylindrically-shaped. Outer side wall **36** may be formed to include a hinged door panel **42** to allow access to interior region **29** of basin **20**. It will be understood that while a single hinged door panel is illustrated in **FIG. 1**, outer side wall **36** may alternatively include more hinged door panels for access to interior region **29** of basin **20**. Illustratively, an upper rim **25** of upper portion **22** defines a mouth of basin **20** that is wider than or includes a diameter greater than the drum with spigot **30** and the tray **18**.

[0017] Bottom wall **38** is formed to include apertures arranged to receive shaft **16**, drain pipe **27**, and water supply line **41**. In the illustrated embodiment, water supply line **41** extends through aperture **40**. Water supply line **41** may be configured so that a source of water is provided, for example, to clean basin **20** or other components of dispenser **12**. Bottom wall **38** may be generally conically-shaped to allow waste liquids to reach outlet **26**.

[0018] Although a generally circular drum **12**, tray **18**, and basin **20** are shown, it should be understood that each of the drum **12**, tray **18**, and/or basin **20** may be configured in any other suitable shape such as, for example, an oval, a square, a rectangle, a triangle, etc. In the case of a square drum, for example, the discharge ports **13** may be spaced-apart along the four walls of the drum. It should also be understood, therefore, that such discharge ports **13** positioned along the four walls of the square drum may be considered to be arranged in a generally 360-degree orientation around the drum.

[0019] In an alternate embodiment contemplated by this disclosure, supply tube **28** is arranged to depend from an overhead source. In this embodiment, supply tube **28** is configured to be coupled to dispenser **12** on an upper portion of drum **14**.

[0020] While the disclosure has been illustrated and described in detail in the foregoing drawings and description, the same is to be considered as illustrative and not restrictive in character, it being understood that only illustrative embodiments thereof have been shown and described and that all changes and modifications that come within the spirit of the disclosure are desired to be protected.

1. An apparatus for distributing a beverage comprising a dispenser configured to be coupled to a shaft, the dispenser having a number of discharge ports coupled to a perimeter of a drum in a spaced-apart relation to one another,

a beverage receptacle platform coupled to the shaft and arranged in spaced-apart relation below the drum, and

a basin including an outer side wall and a bottom wall, the basin surrounding a lower portion of the shaft, the outer side wall and the bottom wall cooperating to define an interior region, the bottom wall being further formed to include an aperture to allow discharge of waste liquids from the basin.

2. The apparatus for distributing a beverage of claim 1, wherein the number of discharge ports are arranged in a generally 360-degree orientation around the drum.

3. The apparatus for distributing a beverage of claim 1, wherein the shaft is formed to include a hollow axial bore configured to receive a beverage supply tube therewithin.

4. The apparatus for distributing a beverage of claim 1, wherein the beverage receptacle platform includes a plate

coupled to the shaft below the drum, the plate extending horizontally away from the shaft and configured to support a beverage receptacle in a position beneath the discharge port to receive a beverage from the discharge port.

5. The apparatus for distributing a beverage of claim 1, wherein each discharge port includes a spigot and a control valve coupled to the spigot, the control valve having a control valve actuator and configured to control the flow of the beverage from the spigot, the control valve actuator configured to allow a user to operate the control valve so that the beverage can be dispensed from the spigot.

6. The apparatus for distributing a beverage of claim 5, wherein each control valve actuator is a palm-receiving rod.

7. The apparatus for distributing a beverage of claim 1, wherein the outer side wall includes a generally frustoconical upper portion coupled to a generally cylindrical lower portion to form a unitary structure.

8. The apparatus for distributing a beverage of claim 7, wherein the basin further includes a first aperture to receive a supply line and a second aperture to receive a waste outlet.

9. An apparatus for distributing a beverage comprising

a central tower,

a dispenser mounted on the central tower including a drum and a number of taps arranged in 360-degree spaced-apart relation around the drum, and

a basin coupled to the central tower and including an outer side wall and a bottom wall formed to include an outlet, the basin being arranged concentrically with the central tower, the central tower extending upwardly from a center portion of the basin.

10. The apparatus for distributing a beverage of claim 9, wherein a beverage receptacle platform is coupled to the central tower below the number of taps, the beverage receptacle platform extending horizontally away from the central tower and configured to receive a beverage receptacle thereon to position the beverage receptacle beneath the number of taps to receive a beverage from the number of taps.

11. The apparatus for distributing a beverage of claim 9, wherein the basin is concentrically arranged with the dispenser.

12. The apparatus for distributing a beverage of claim 11, wherein the bottom wall is generally conically-shaped to drain liquids toward the outlet.

13. The apparatus for distributing a beverage of claim 9, wherein the drum of the dispenser is annular.

14. The apparatus for distributing a beverage of claim 9, wherein the drum of the dispenser is rectangular.

15. The apparatus for distributing a beverage of claim 9, wherein the dispenser includes a supply line in fluid communication with the number of taps and configured to be coupled to a beverage source.

16. The apparatus for distributing a beverage of claim 15, wherein the central tower is a hollow shaft configured to receive the supply line.

17. The apparatus for distributing a beverage of claim 15, wherein the supply line is coupled to the dispenser and arranged to depend from an overhead structure.

18. An apparatus for distributing a beverage comprising

a vertical shaft including a supply line adapted to be coupled to a beverage supply source,

a drum mounted to the vertical shaft including a number of discharge ports arranged in spaced-apart relation 360-degrees around the drum, the discharge ports being in fluid communication with the supply line,

a beverage receptacle platform coupled to the vertical shaft below the drum and extending radially outwardly therefrom, and

a basin coupled to the vertical shaft having a waste outlet, the basin positioned below the beverage receptacle platform, concentrically aligned with the drum and

having a mouth portion wider than the drum and a generally conically-shaped bottom wall to allow fluid access to the waste line.

19. The apparatus for distributing a beverage of claim 18, further comprising a water supply line coupled to the basin.

20. The apparatus for distributing a beverage of claim 18, wherein the basin includes a port to provide access to an interior portion of the basin.

* * * * *